



**FURNITURE  
& FITTINGS  
SKILL COUNCIL**  
कुशल • सक्षम • आत्मनिर्भर

# **CLOSURE REPORT**

**Recognition of Prior Learning (RPL) Program**

**of**

**Wood Workers and allied Workforce**

**of**

**Furniture & Fittings Sector**

**Submitted To:**

Commonwealth Educational Media Centre for Asia (CEMCA)



**By:**

Furniture & Fittings Skill Council (FFSC)



## Content

S. No.	Topic	Page Number
1	Introduction	3
2	Objective of the Program	4
3	The RPL Program	4
4	RPL Training Outcome	6
5	Trainer/ Speaker Name	10
6	The Financials	11
7	Certificate Distribution	11
8	Training Photographs	13
9	Certificate Distribution Photographs	15
10	Results	17
11	Attendance Sheet	26



## 1. Introduction

### Commonwealth Educational Media Centre for Asia (CEMCA)

Commonwealth Educational Media Centre for Asia (CEMCA) was established in the year 1994 in response to needs expressed by Commonwealth countries of the Asian region for more effective utilization of educational media resources. The vision of CEMCA is to be the foremost agency in Commonwealth Asia that promotes media-enabled learning for development. CEMCA is also engaged in Skill Development for a better livelihood for youth.

### Furniture & Fittings Skill Council (FFSC)

Furniture & Fittings Skill Council (FFSC) is an Industry-led Not-for-Profit organization, registered under the Societies Registration Act XXI of 1860. It operates under the aegis of the Ministry of Skill Development and Entrepreneurship (MSDE). The sector skill council aims to focus on establishing an effective and efficient eco-system for development and imparting of skills for the Furniture & Fittings industry including the development of relevant curriculum, courses, information database, delivery system, standardization, accreditation and certification processes to enhance the employability of the Indian workforce globally. FFSC has created the platform to scale up the operations and benefit the industry at large.

The industry players from various sub-sectors such as manufacturing, wood, panel, adhesives, fittings, etc. come together at FFSC to collaborate and contribute to making the industry more competitive.





**FURNITURE  
& FITTINGS  
SKILL COUNCIL**

कुशल • सक्षम • आत्मनिर्भर



#### FFSC JOURNEY: 2015 TILL 2021 (SNAPSHOT)



- 70+** Industries & Associates
- 22** Industry Recognised Job Roles
- 40+** Associated Training Partners
- 160+** Associated Trainers
- 250+** Associated Assessors
- 180000+** Certified under RPL Program
- 15000+** Certified under STT Program
- 200+** Enrolled as Apprentice
- 250+** Participants completed in WSC 2019

## 2. The Objective of the Program

- To mobilize and identify 250 workers of woodworking and allied sectors for the Recognition of Prior Learning (RPL) programme
- To design and develop RPL training and assessment programme for 250 workers of woodworking and allied sectors.
- To organize 12 hours of RPL training programme and assessments using the following modality and pedagogy:
  - Document collection and Selection
  - Counselling and Pre-screening
  - Orientation and Training
  - Final Assessment
  - Certification and Award Ceremony

## 3. The RPL Program

A huge section of India's unorganized workforce is unskilled and semi-skilled. Most of them pick up skills and knowledge in an informal set-up by observing people or working under their guidance or through complete self-learning. Even though they manage to get a job and earn a decent wage or salary, they do not have any formal certification of their skills. This also affects



their prospects of getting decent employment opportunities. This is where Recognition of Prior Learning (RPL) can help them get assessed and certified on their current competencies as per NSQF levels. RPL also shows them a path to bridge their current knowledge and skill levels to reach a competency level or go for higher skills for professional growth. It is a platform to provide recognition to informal learning or learning through work to get equal acceptance as the formal levels of education. It aims to appreciate prior learning irrespective of the medium of achieving it. In short, RPL is a process of assessment of an individual's prior learning to give due importance to learning as an outcome rather than learning as a process.

#### **a. Pre-training Activities**

- Identification and mobilization of potential candidates
- Shortlisting of the 250 workers of woodworking and allied sectors for the RPL programme through pre-screening and counselling
- Workers shortlisted from New Delhi, Udaipur (Rajasthan), and Singur (West Bengal)

#### **b. Training Activities**

Training of 12 hours provided to the candidates by the Industry and Subject Matter Experts. The Indian Postal Payment bank also imparted financial literacy training to the candidates.

#### **The 12 hours training program focusing on:**

- Scope of furniture and fitting industry
- Importance of skilling
- Scope of woodworkers
- Recycling of waste wood
- Understanding organization context
- Health and safety at the workplace
- Communication skills
- Financial literacy session by India Payment Postal Bank
- Digital literacy training program by experts
- Domain training sessions by Industry (Hettich India and Ozone Overseas Pvt Ltd)

#### **Assessment and Tool Kit Distribution**

- Assessment of the candidates done after 12 hours of training
- Certificate, T-shirt, cap, bag and tool kits distributed to the certified candidates



## 4. RPL Training Outcome

Following are the training outcome of the RPL training program:

### a. Scope in the Furniture Industry

- Discuss the Indian furniture industry, growth drivers, and market structure
- Discuss an overview of the furniture industry in India
- Assess the employment opportunities in the industry
- Assess the critical growth drivers in the furniture industry

### b. Introduction to Skill Ecosystem

- Define Skill India Mission
- Define skilling and implication of skilling
- Describe the importance of the requirement of upskilling/reskilling/ multi-skilling
- Describe Furniture & Fittings Skill Council
- Define RPL and STT certification process and its significance
- Describe WorldSkills Competition

### c. Scope of Woodworkers

- Define the roles and responsibilities
- Analyze the career progression in the furniture industry
- Discuss the requisites of woodworker and allied workforce
- List the responsibilities of a woodworker and allied workforce
- Evaluate the skills essential for a woodworker and allied workforce

### d. Recycling of Waste Wood

- Define waste wood and waste wood recycling
- Describe ways of waste wood recycling
- Describe new opportunities for waste wood recycling
- Describe benefits of waste wood recycling

### e. Understanding Organization Context

- Describe general discipline in the workplace
- Describe organizations rules and regulations
- Summarize basic skills of communication

### f. Health and Safety at the Workplace

- Describe effective working mechanism during COVID-19 pandemic
- Identify potential hazards and risks at workshop or site
- Learn about dealing with potential hazards and risks
- Learn about preventive measures to minimize the potential hazards and risks





- Learn about treating common injuries by giving first-aid
- Summarize things to be done during an emergency

**g. Communication Skills**

- Evaluate the importance of communication
- Identify the methods of communication
- Demonstrate skills of communication effectively

**h. New Opportunities in the Woodworking Industries**

- Describe new machining tools with their usage
- Describe power tools and their safety measures

**i. Financial Literacy**

- Explain about types of bank account
- Explain the process of opening a bank account
- Describe fixed and variable costs
- Describe online banking NEFT, RTGS etc
- Describe types of payment methods like cash, cheques, cards, bank transfers etc
- Explain the usage of various payment gateways BHIM, Paytm, Phonepe etc.

**j. Digital Literacy**

- Describe basics of computer and internet
- Describe types of digital communication channels, video, email, social media
- Describe the importance and usage of various social media platforms like WhatsApp, Facebook, Twitter etc.
- Explain about significance and use of Digi locker

The training focused on improving the skills and working abilities of a woodworker and allied workforce. Woodworker requires training, which involves the acquisition of both knowledge and physical practice. An efficient worker should have technical knowledge and skills to perform well. Some basic technical skills which were emphasized:

- Reading technical drawings
- Use of the measuring and marking tools
- Cutting material using cutting tools
- Checking level, plumb and square of the work done
- Driving screws and nails, drilling, hammering, etc.

In addition to essential technical knowledge and skills, a woodworker should also possess certain soft skills, or personal qualities, namely:

- Good communication skill
- Detail-oriented nature
- Good hand and eye coordination
- Physical fitness
- Good sense of personal hygiene
- Honesty
- Ability to work in a team
- Trustworthy
- Ability to solve problems
- Hard-working nature
- Punctuality
- Courteous and dedicated nature

The RPL training program has helped the workers to gain technical and professional skills essential for efficient woodworkers.

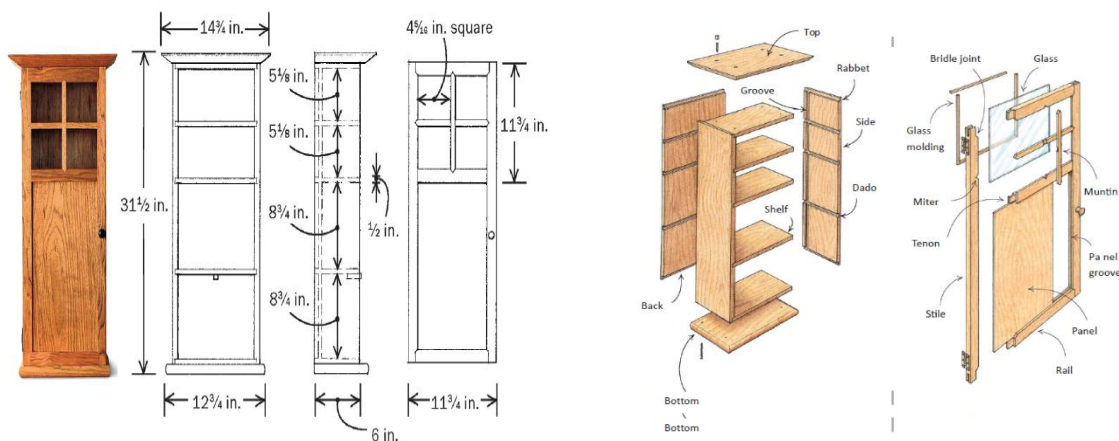

*Sample technical drawing*



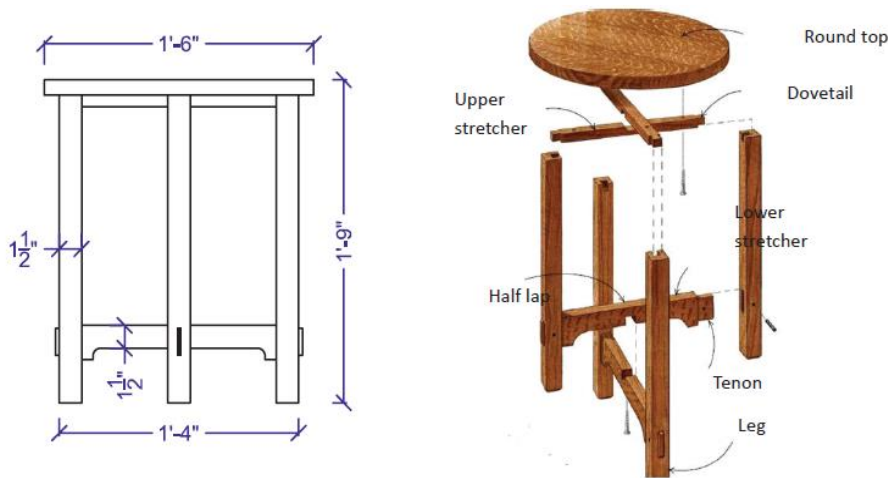

Sample round table drawing

The details of the completed RPL training program are:

S. No.	Job role	Location	No. enrolled	No. assessed	No. Passed	No. Failed	No. Did not appear
1	Lead Carpenter Wooden Furniture, Level-4	New Delhi	29	23	23	0	0
2	Lead Carpenter Wooden Furniture, Level-4	Udaipur, Rajasthan	28	26	26	0	0
3	Lead Carpenter Wooden Furniture, Level-4	Udaipur, Rajasthan	40	30	30	0	0
4	Lead Carpenter Wooden Furniture, Level-4	Udaipur, Rajasthan	40	38	38	0	0
5	Lead Carpenter Wooden Furniture, Level-4	Udaipur, Rajasthan	44	44	44	0	0
6	Lead Carpenter Wooden Furniture, Level-4	Udaipur, Rajasthan	30	30	30	0	0
7	Assistant Carpenter Wooden Furniture, Level-3/ Lead Carpenter Wooden Furniture, Level-4	Singur, West Bengal	61	61	61	0	0
<b>Total</b>			<b>272</b>	<b>252</b>	<b>252</b>	<b>0</b>	<b>0</b>



## 5. Trainer/ Speaker Name

S. No.	Location	Batch Start Date	Batch End Date	Assessment date	Speaker/ Trainer Name
1	New Delhi	11 April 2021	12 April 2021	12 April 2021	Mr Rahul Mehta Mr Devesh Sharma Mr Mohit Mr Deepak Shukla Mr Rajan Srivastava Mr Susham Banerjee Mr Shubham Gandhi
2	Udaipur, Rajasthan	24 June 2021	25 June 2021	25 June 2021	Mr Rahul Mehta Mr Manish Suhalka Mr Abhishek Dewaliya Mr Pradeep Nagda Mr. Dushyant Bhatnagar Mr Shubham Gandhi
3	Udaipur, Rajasthan	25 June 2021	26 June 2021	26 June 2021	Mr Rahul Mehta Mr Lokesh Sahu Mr Abhishek Dewaliya Mr Pradeep Nagda Mr Dinesh Kumar Nagda Mr Shubham Gandhi
4	Udaipur, Rajasthan	26 June 2021	27 June 2021	27 June 2021	Mr Rahul Mehta Mr Manish Suhalka Mr Dinesh Kumar Nagda Mr. Dushyant Bhatnagar Mr Abhishek Dewaliya Mr Pradeep Nagda
5	Udaipur, Rajasthan	26 June 2021	27 June 2021	27 June 2021	Mr Rahul Mehta Mr Lokesh Sahu Mr Abhishek Dewaliya Mr Pradeep Nagda Mr Dinesh Kumar Nagda Mr Shubham Gandhi
6	Udaipur, Rajasthan	27 June 2021	28 June 2021	28 June 2021	Mr Pradeep Nagda Mr Lokesh Sahu Mr Abhishek Dewaliya Mr Shubham Gandhi Mr Dushyant Bhatnagar
7	Singur, West Bengal	26 June 2021	27 June 2021	27 June 2021	Mr Anil Mr Chirag Mr Mohit Mr Susham Banerjee Mr Subhankar Chakraborty



## 6. The Financials

S. No.	Component	Description	The rate in INR/ Qty in the number
1	RPL training and assessment cost per participant	<ul style="list-style-type: none"> <li>Trainer fee</li> <li>Mobilization of participants</li> <li>Expense on research for the development, of course, study material etc.</li> <li>The management fee for engaging industry and other relevant stakeholders</li> <li>Assessment and certification fee</li> </ul>	2750 (2000 for training and 750 for assessment and certification)
2	Number of beneficiaries planned for pilot		250
3	<b>Total Amount (No GST)</b>		<b>6,87,500</b>
4	<b>Contribution from FFSC</b>	FFSC will be contributing with a toolkit worth 750 to each certified candidate	<b>1,87,500</b>

## 7. Certificate Distribution

The NSQF aligned certificate provides an opportunity to the candidate to get employment or a higher level of skill certification. The certification after the RPL program gives recognition to the candidates for their acquired skills.

FFSC ensures that all the candidates who undergo training are rigorously assessed on various parameters like domain and non-core skills.

FFSC has organized a certificate distribution ceremony for all the pass candidates at different locations. A tool kit comprising 2 in 1 screwdriver, hammer, chisel with handle, try square, oil stone, measurement tape, and hand saw was given to all the candidates along with the certificates.

T-shirts, caps and bags were also provided to the trainees for motivating them.





The guests emphasized the importance of the Skill Certificate and the scope in the furniture and fittings sector. The guests motivated the candidates and shared the continued importance of skilling, reskilling and upskilling. The certificates distribution ceremony and interaction with candidates were done by adhering to the prevention protocols of COVID-19. Details of the certificate distribution program are:

Location	Date of certificate distribution
Udaipur, Batch-1	13 <sup>th</sup> August 2021
Udaipur, Batch-2	23 <sup>rd</sup> July 2021
Udaipur, Batch-3	23 <sup>rd</sup> July 2021
Udaipur, Batch-4	23 <sup>rd</sup> July 2021
Udaipur, Batch-5	2 <sup>nd</sup> August 2021
Singur	25 <sup>th</sup> July 2021
New Delhi	9 <sup>th</sup> August 2021

Location	Guests Present during the certificate distribution ceremony
New Delhi	Mr Parth Mahajan, Operation Manager, Zorin Furniture Mr Devesh Sharma, FFSC Mr Shrikanth Sasi, FFSC Mr Rajan Srivastava, FFSC
Udaipur, Rajasthan	Batch-2 Mr Manan Khaitan, Director, Iraj Evolution Mr Arun Mandot, Chairman, ISTD Mr Rajkumar Bagora, Principal of CETT Mr Rahul Mehta, CEO, FFSC Batch-3 Mr Lokendra, Founder, Wooden Street Mr Virendra, Founder, Wooden Street Batch-4 Mr Anand Sharma, Director, Jhangid Furniture Mr Dilip Jain, Director, Bharat Furniture Mr Devendra Minda, Director, Minda Furniture Mr Shailesh Tank, Director, Hansa Udhog Mr Shailendra Josh, Director, Liberty Bhawna Enterprises Batch-5 Dr C. K. Trivedi - Ayurvedic Health Officer, Khakhad, Jhadol Mrs Radha Devi - Panchayat Samiti Sadasya, Jhadol, Udaipur Mr Pradeep Nagda - Managing Director, Visvesvaraya Foundation, Udaipur
Singur, West Bengal	Mr Subhankar Chakraborty, STS Mr Susham Banerjee, FFSC





**FURNITURE  
& FITTINGS  
SKILL COUNCIL**

कुशल • सक्षम • आत्मनिर्भर

## 8. Training Photographs





**FURNITURE  
& FITTINGS  
SKILL COUNCIL**  
कुशल • सक्षम • आत्मनिर्भर







**FURNITURE  
& FITTINGS  
SKILL COUNCIL**

कुशल • सक्षम • आत्मनिर्भर

## 9. Certification Distribution Photographs





**FURNITURE  
& FITTINGS  
SKILL COUNCIL**  
कुशल • सक्षम • आत्मनिर्भर







## 10.Results

### a. Batch-1 New Delhi

S. No.	Name	% of marks	Remarks
1	Tejpal	82	Pass
2	Ramdulare	84	Pass
3	Prem Prakash	88	Pass
4	Shatrudhan Singh	85	Pass
5	Praveen Kumar	84	Pass
6	Sushil Kimar	84	Pass
7	Durgesh	82	Pass
8	Dileep Kumar	90	Pass
9	Monu	83	Pass
10	Shakil	80	Pass
11	Prem Narayan	77	Pass
12	Prabhunath Prajapati	85	Pass
13	Naresh Sharma	85	Pass
14	Naresh Sharma	75	Pass
15	Suresh Singh	81	Pass
16	Niranjan Kumar	76	Pass
17	Babu Khan	87	Pass
18	Mohd. Farukh	76	Pass
19	Dharamveer	86	Pass
20	Sadhu	72	Pass
21	Jitendra	73	Pass
22	Sudershan	80	Pass
23	Arvind	78	Pass

### b. Batch- 2, Udaipur

S. No.	Name	% of marks	Remarks
1	Mahendar Singh	80	Pass
2	Raju Suthar	84	Pass
3	Balkishan	87	Pass



4	Santosh Kumar	85	Pass
5	Puran Singh Shekhawat	85	Pass
6	Nathu Singh	84	Pass
7	Rajendra Singh	81	Pass
8	Om Prakash	90	Pass
9	Manish Sharma	80	Pass
10	Shahrukh Mohmmad	79	Pass
11	Dhanpat	72	Pass
12	Lachharam	85	Pass
13	Bajrang Lal Jangir	88	Pass
14	Shubham	71	Pass
15	Moti Lal	70	Pass
16	Hariram	87	Pass
17	Rajuram	76	Pass
18	Mithalal Suthar	86	Pass
19	Jogaram	72	Pass
20	Dinesh	70	Pass
21	Chandra Prakash Jangid	78	Pass
22	Dinesh	83	Pass
23	Swai K Mistry	86	Pass
24	Babulal	86	Pass
25	Tahgeev	76	Pass
26	Jethu Singh	73	Pass

**c. Batch-3, Udaipur**

S. No.	Name	% of marks	Remarks
1	Shravan Jangid	77	Pass
2	Sanjay Sharma	84	Pass
3	Sinod Kumar	75	Pass
4	Devendra Thakur	79	Pass
5	Ramsey Jangid	74	Pass



6	Jagdish Rao	72	Pass
7	Dev Kishan Suther	80	Pass
8	Mehera Ram	72	Pass
9	Vijay Sharma	77	Pass
10	Ravindra Sharma	76	Pass
11	Mukesh Ved	73	Pass
12	Rakesh Lohar	70	Pass
13	Bansi Lal	75	Pass
14	Vikas Dahiyma	80	Pass
15	Madan Dangi	70	Pass
16	Prakash Lal Lohar	77	Pass
17	Ashok Dasora	75	Pass
18	Sunil Kumar Sharma	70	Pass
19	Bhala Ram	75	Pass
20	Lakha Ram	70	Pass
21	Jagdish Prasad Jat	71	Pass
22	Manish Sharma	70	Pass
23	Sohan Lal Suther	76	Pass
24	Vikas Dangi	70	Pass
25	Ganesh	74	Pass
26	Dharmendra Lohar	81	Pass
27	Shankar Gurjar	72	Pass
28	Anil Jangid	80	Pass
29	Jitendra Sharma	78	Pass
30	Shankar Lal Panwar	80	Pass

**d. Batch-4, Udaipur**

S. No.	Name	% of marks	Remarks
1	Prakash Chandra suthar	78	Pass
2	Ravi Shankar suthar	77	Pass
3	Ram chandra Suthar	84	Pass
4	Rajendar kumar suthar	79	Pass



5	Sunil Suthar	78	Pass
6	Mukesh lohar	73	Pass
7	Raghuveer lohae	72	Pass
8	Mohammad Tasleem	83	Pass
9	Kamal saarma	82	Pass
10	Gourav Suthar	70	Pass
11	Pushkar sharma	85	Pass
12	Mohd mahtab	80	Pass
13	Vaseem Akram	70	Pass
14	Satyesh suthar	77	Pass
15	Himmat lal suthar	84	Pass
16	Mangi lal jain	86	Pass
17	Tejpal lohar	86	Pass
18	Ramesh chndr lohar	86	Pass
19	Mahendra Kumar Lohar	71	Pass
20	Sunil lohar	72	Pass
21	Kailash chandra suthar	83	Pass
22	AmiR.Ahmid	82	Pass
23	Mohammed Ebran	82	Pass
24	Laxmi lal suhtar	85	Pass
25	Gopal suthar	83	Pass
26	Sonu lohar	82	Pass
27	Bilal khan	75	Pass
28	Devi lal suthar	88	Pass
29	Prahlad Suthar	82	Pass
30	Kailash Sharma	75	Pass
31	Om Prakash Suthar	85	Pass
32	Devender Suthar	86	Pass
33	Ansar Mohmmad	76	Pass
34	Azim	82	Pass
35	Nirmal Suthar	78	Pass





36	Pushkar Lal Dangi	73	Pass
37	Ramchandra Suthar	86	Pass
38	Mukesh Lohar	86	Pass

**e. Batch-5, Udaipur**

S. No.	Name	% of marks	Remarks
1	Shantil Trivedi	74	Pass
2	Dinesh Suthar	82	Pass
3	Kishan Lal	79	Pass
4	Mangil Lohar	83	Pass
5	Rajendra Kumar Suthar	76	Pass
6	Pushkar Suther	70	Pass
7	King Kulambi	70	Pass
8	Ram Lal Suthar	89	Pass
9	Manish Suther	70	Pass
10	Fateh Lal	82	Pass
11	Vikram Suthar	70	Pass
12	Maganlal	74	Pass
13	Manoj Suther	76	Pass
14	Prbhu Lal Lohar	84	Pass
15	Gyan Singh Rajput	77	Pass
16	Vishnu Shankar Dave	74	Pass
17	Om Prakash Dave	78	Pass
18	Dadam Chand	80	Pass
19	Nathu Lal Suthar	73	Pass
20	Suresh	75	Pass
21	Kanu Kulmi	70	Pass
22	Ganesh Lal Prajapat	70	Pass
23	Raju Lal Patel	75	Pass
24	Bhupendra Suther	74	Pass
25	Govind Ram Suthar	75	Pass



26	Mohanlal Suthar	89	Pass
27	Pannalal Lal	82	Pass
28	Ashok Suthar	85	Pass
29	Kalu Lal	76	Pass
30	Ramlal	84	Pass
31	Nanalal	90	Pass
32	Parbhu Lal Suther	85	Pass
33	Lakshmi Ram	74	Pass
34	Prem Shankar	73	Pass
35	Tushar Suther	70	Pass
36	Kalu Lal Suthar	75	Pass
37	Dilip Kumar	70	Pass
38	Shankar Lal	76	Pass
39	Beru Lal	80	Pass
40	Kalu Lal Suthar	77	Pass
41	Nathu Lal	82	Pass
42	Gopal Suther	90	Pass
43	Durga Shankar	75	Pass
44	Rama	75	Pass

**f. Batch -6, Udaipur**

S. No.	Name	% of marks	Remarks
1	Punam Chand Kharadi	76	Pass
2	Arvind	78	Pass
3	Sankarlal	80	Pass
4	Haridev	74	Pass
5	Vasudev	76	Pass
6	Nikhil Pandora	75	Pass
7	Rakesh Kumar	77	Pass
8	Ranjit Kumar	77	Pass
9	Bhupesh Pandora	76	Pass



10	Jagdish Kumar Baghora	78	Pass
11	Harish	75	Pass
12	Nayanesh Kumar	73	Pass
13	Mahesh Kumar	76	Pass
14	Dinesh Kumar	74	Pass
15	Badrilal	76	Pass
16	Shanti Lal	74	Pass
17	Vijay	71	Pass
18	Ram Lal	76	Pass
19	Chandresh Pandora	71	Pass
20	Rohit Kumar	73	Pass
21	Kalpesh	75	Pass
22	Khaniyal	71	Pass
23	Anil Kumar Bhagora	80	Pass
24	Harish	71	Pass
25	Shambhulal	70	Pass
26	Jitendra Kumar	71	Pass
27	Chunni Lal	73	Pass
28	Rangre Lal	74	Pass
29	Chimman	73	Pass
30	Panalal	75	Pass

**g. Batch-7, Singur**

S. No.	Name	% of marks	Remarks
1	Malay Kumar Koley	70	Pass
2	Milan Koley	88	Pass
3	Sukhen Bhowmick	87	Pass
4	Amitava Das	88	Pass
5	Dinesh Das	74	Pass
6	Kaushik Koley	72	Pass
7	Somnath Das	85	Pass
8	Proloy Das	73	Pass



9	Krishna Chandra Santra	90	Pass
10	Achinta Dhara	75	Pass
11	Subrata Dhara	72	Pass
12	Akash Dhara	72	Pass
13	Samir Dhara	81	Pass
14	Nilkanto Koley	75	Pass
15	Subhajit Santra	88	Pass
16	Ranjit Koley	74	Pass
17	Supriyo Sasmal	71	Pass
18	Swarup Das	72	Pass
19	Sujit Majhi	76	Pass
20	Deb Kumar Santra	89	Pass
21	Hritwick Santra	70	Pass
22	Prosenjit Das	74	Pass
23	Subir Koley	88	Pass
24	Santu Das	78	Pass
25	Soumen Koley	73	Pass
26	Rajkumar Bag	88	Pass
27	Kanai Bar	89	Pass
28	Tarun Kumar Das	77	Pass
29	Jhantu Koley	75	Pass
30	Arjun Dhara	74	Pass
31	Subhra Adhikary	85	Pass
32	Laltu Das	85	Pass
33	Jagannath Ghanti	75	Pass
34	Ananda Koley	76	Pass
35	Suvankar Bag	76	Pass
36	Nabakumar Dhara	76	Pass
37	Hemanta Koley	86	Pass
38	Surajit Adak	76	Pass
39	Utpal Santra	89	Pass



40	Tarun Singh	76	Pass
41	Uttam Koley	88	Pass
42	Rajkumar Koley	87	Pass
43	Banamali Bar	87	Pass
44	Goutam Koley	89	Pass
45	Samir Ghosh	76	Pass
46	Mintu Ghosh	73	Pass
47	Tapas Das	74	Pass
48	Santu Das	76	Pass
49	Sumit Das	70	Pass
50	Ramesh Singh	86	Pass
51	Ujjwal Koley	71	Pass
52	Chiranjit Das	70	Pass
53	Sukumar Malik	77	Pass
54	Abhas Samanta	74	Pass
55	Sanju Mondal	75	Pass
56	Saila Dhara	77	Pass
57	Basanta Roy	86	Pass
58	Subhajit Maity	70	Pass
59	Pratap Raj Das	89	Pass
60	Rajkumar Santra	77	Pass
61	Uday Das	87	Pass



**FURNITURE  
& FITTINGS  
SKILL COUNCIL**  
कुशल • सक्षम • आत्मनिर्भर

## 11. Attendance sheet of each batch

The attendance sheets of each batch are attached as **Annexure 1**.